

Angle Seat Valve(Piston Valve) Series PV100 (Threaded Ends)

◆ Dimensions [mm]

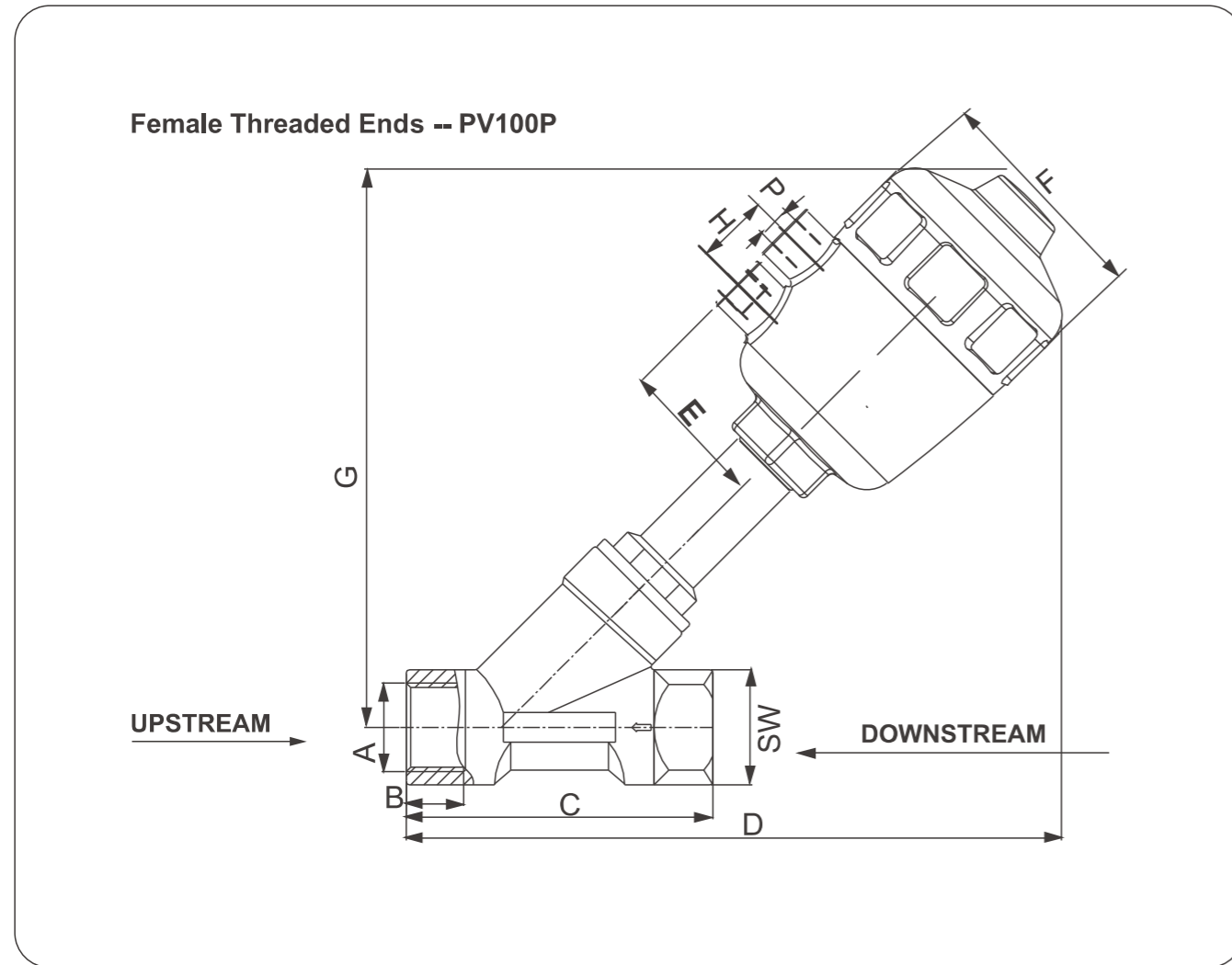

Port Size	DN (mm)	Actuator (mm)	A	B	C	D	E	F	G	H	P	SW
3/8"	DN10	40	G3/8	12	65	142	30	53	85	20	G1/8	25
		50	G3/8	12	65	145	44	64	100	24	G1/4	25
1/2"	DN15	40	G1/2	14	76	162	30	53	115	20	G1/8	28
		50	G1/2	14	76	168	44	64	115	24	G1/4	28
3/4"	DN20	50	G3/4	16	92	175	44	64	131	24	G1/4	32
		63	G3/4									
1"	DN25	50	G1	21	103	186	44	64	138	24	G1/4	39
		63	G1	21	103	218	54	79.5	166	24	G1/4	39
1-1/4	DN32	63	G1-1/4	19	112	228	54	79.5	172	24	G1/4	49
1-1/2	DN40	63	G1-1/2	21	129	232	54	79.5	174	24	G1/4	56
2"	DN50	63	G2	27	143	252	54	79.5	193	24	G1/4	68
		80	G2	27	143	263	62	101	202	24	G1/4	68
2-1/2"	DN65	80	G2-1/2	28	186	280	62	101	209	24	G1/4	84
3"	DN80	100	G3	34	218	355	71	125	268	30	G1/4	101

Angle Seat Valve(Piston Valve) Series PV100 (Threaded Ends)

◆ Dimensions [mm]

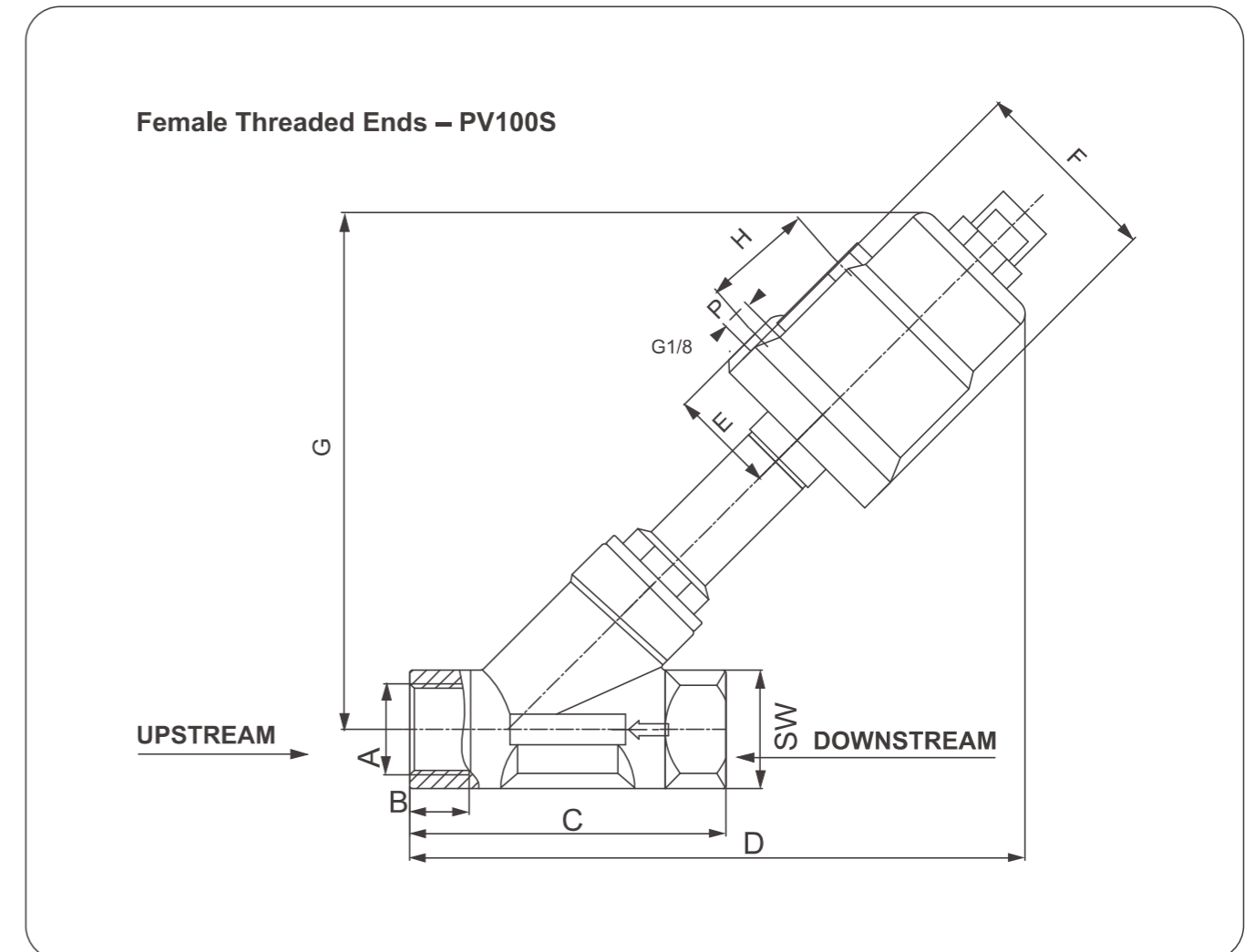

Port Size	DN (mm)	Actuator (mm)	A	B	C	D	E	F	G	H	P	SW
3/8"	DN10	40	G3/8	12	65	144	28	53	105	38	G1/8	25
		50	G3/8	12	65	//	35	56	//	38	G1/8	25
1/2"	DN15	40	G1/2	14	76	157	28	53	113	38	G1/8	28
		50	G1/2	14	76	182	35	56	142	38	G1/8	28
3/4"	DN20	50	G3/4	16	92	189	35	56	152	38	G1/8	32
		63	G3/4	16	92		43	70		44	G1/8	32
1"	DN25	50	G1	21	103	207	35	56	155	38	G1/8	39
		63	G1	21	103	217	43	70	176	44	G1/8	39
1-1/4	DN32	63	G1-1/4	19	112	222	43	70	177	44	G1/8	49
1-1/2	DN40	63	G1-1/2	21	129	225	43	70	182	44	G1/8	56
2"	DN50	63	G2	27	143	249	43	70	196	44	G1/8	68
		90	G2	27	143	268	56	94	206	67	G1/4	68
2-1/2"	DN65	90	G2-1/2	28	186	290	56	94	215	67	G1/4	84
3"	DN80	125	G3	34	218	335	73	135	295	67	G1/4	101