

## AD Series Auto Drainer:

a) AD200, AD200C series:



### 1. Ordering Code :

AD	-	200	-	□
↑		↑		↑
Model		Size		Thread type
Auto Drainer		200		Blank: G1/8 female
		200C (with cup)		M: G1/8 male
		300		
		400		

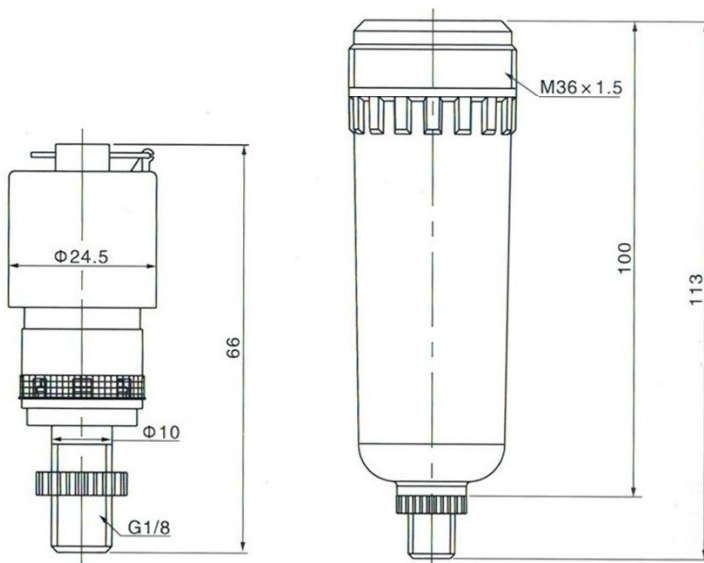

Dimensional drawing of water cup conneting part

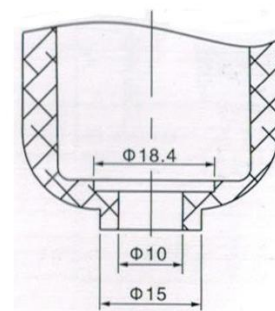

### 2.Characteristics:

- 1) This product is installed at the bottom of water cups which are automatic drainers, air filters.
- 2) It can auto-discharge the condense water gathered in the water cup.
- 3) The auto-drainer should be vertically and the drain port towards down for installation.

## 3.Specification:

Model	AD200-M/F	AD300-M/F	AD400-M/F
Applicable medium	Compressed Air		
Working pressure range	0.2~0.8 MPa		
Proof pressure	1.2MPa		
Working Temperature range	5℃~60℃		
Bottom drain port size	G1/8 male or female		
Applicable for:	AF2000 or AW2000	AF3000 or AW3000	AF,AW4000/5000

### b) AD300 series:



AD300



AD300-M

c) AD400 series:



AD300



AD300-M

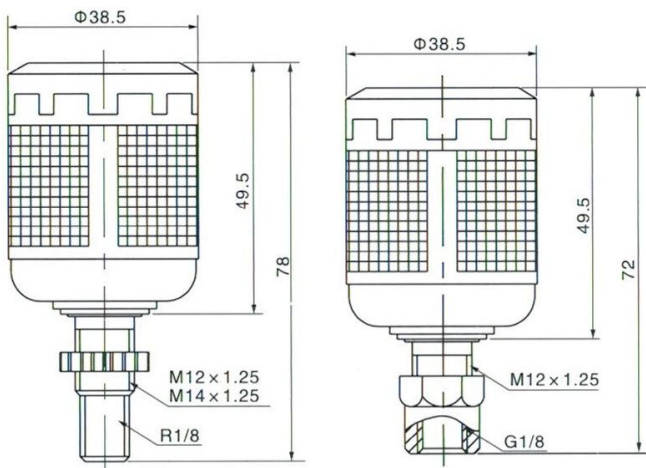

Dimensional drawing of water cup connecting part

